

vtech[®]

Parent's Guide

Marble Rush™ Adventure Set

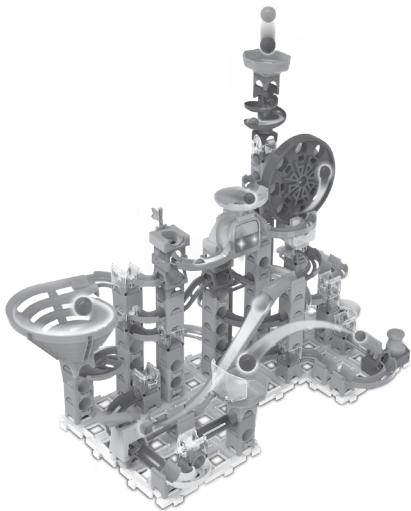

VTech understands that a child's needs and abilities change as they grow and with that in mind we develop our toys to teach and entertain at just the right level...

vtech Baby

Toys that will stimulate their interest in different textures, sounds and colours

I am...

...responding to colours, sounds and textures

...understanding cause and effect

...learning to touch, reach, grasp, sit-up, crawl and toddle

Birth-36 months



Pre-School

Interactive toys to develop their imagination and encourage language development

I want...

...to get ready for school by starting to learn the alphabet and counting

...my learning to be as fun, easy and exciting as can be

...to show my creativity with drawing and music so my whole brain develops

3-6 years



Electronic Learning Computers

Cool, aspirational and inspiring computers for curriculum related learning

I need...

...challenging activities that can keep pace with my growing mind

...intelligent technology that adapts to my level of learning

...National Curriculum based content to support what I'm learning at school

4-10 years



To learn more about this and other VTech® products, visit www.vtech.co.uk

INTRODUCTION

Thank you for purchasing the **Marble Rush™ Adventure Set!** Get ready for non-stop action! Build thrilling courses, send the marbles into motion and compete with family and friends through exciting challenges complete with sounds and lights. Please refer to the colour manual for detailed assembly steps.

INCLUDED IN THIS PACKAGE

- Marble Rush™ Adventure Set
- Parent's guide
- Colour manual

WARNING:

All packing materials such as tape, plastic sheets, packaging locks, removable tags, cable ties, cords and packaging screws are not part of this toy and should be discarded for your child's safety.

NOTE: Please keep this Parent's Guide as it contains important information.

INSTRUCTIONS

Battery Removal and Installation

1. Make sure the unit is turned **OFF**.
2. Locate the battery cover on the back of the unit. Use a screwdriver to loosen the screw. Then, remove the cover.
3. If used batteries are present, remove these batteries from the unit by pulling up on one end of each battery.
4. Install 2 new AA (AM-3/LR6) / 3 new AAA (LR03/AM-4) batteries following the diagram inside the battery box. (For best performance, alkaline batteries or fully charged Ni-MH rechargeable batteries are recommended).

2

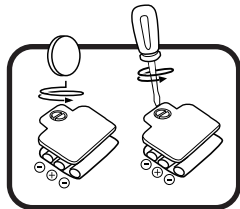
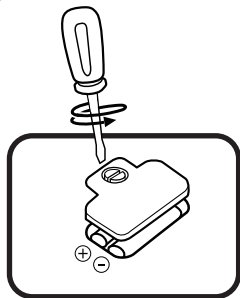

5. Replace the battery cover and tighten the screw to secure.

WARNING:

CHOKING HAZARD -Toy contains small parts and small balls. Not for children under 3yrs.

WARNING:

Adult assembly required for battery installation.

Keep batteries out of reach of children.

WARNING:

Do not aim at eyes or face.

IMPORTANT: BATTERY INFORMATION

- Insert batteries with the correct polarity (+ and -).
- Do not mix old and new batteries.
- Do not mix alkaline, standard (carbon-zinc) or rechargeable batteries.
- Only batteries of the same or equivalent type as recommended are to be used.
- Do not short-circuit the supply terminals.
- Remove batteries during long periods of non-use.
- Remove exhausted batteries from the toy.
- Dispose of batteries safely. Do not dispose of batteries in fire.

RECHARGEABLE BATTERIES:

- Remove rechargeable batteries from the toy before charging.
- Rechargeable batteries are only to be charged under adult supervision.
- Do not charge non-rechargeable batteries.

Australia/New Zealand:

If you think batteries might have been swallowed or placed inside any part of the body, immediately call the 24-hour Poisons Information Centre on 13 11 26 (in Australia) or 24-hour National Poisons Centre on 0800 764 766 (in New Zealand) for fast, expert advice and go straight to the nearest hospital emergency room.

Disposal of batteries and product

The crossed-out wheellie bin symbols on products and batteries, or on their respective packaging, indicates they must not be disposed of in domestic waste as they contain substances that can be damaging to the environment and human health.



The chemical symbols Hg, Cd or Pb, where marked, indicate that the battery contains more than the specified value of mercury (Hg), cadmium (Cd) or lead (Pb) set out in the Batteries and Accumulators Regulation.

The solid bar indicates that the product was placed on the market after 13th August, 2005.

Help protect the environment by disposing of your product or batteries responsibly.



VTech® cares for the planet.

 Care for the environment and give your toy a second life by disposing of it at a small electricals collection point so all its materials can be recycled.

In the UK:

Visit www.recyclenow.com to see a list of collection points near you.

In Australia & New Zealand:

Check with your local council for kerbside collections.

LABEL APPLICATION

Please securely stick the labels to the play set as indicated below:

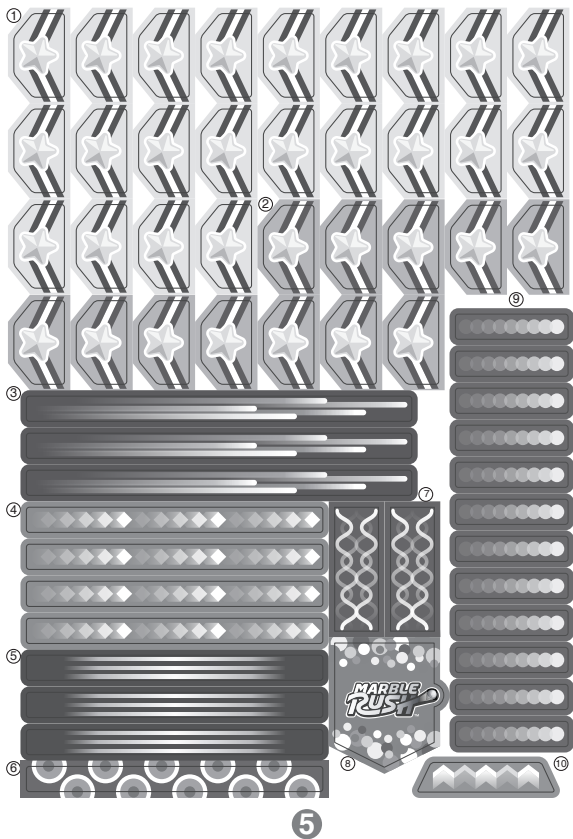

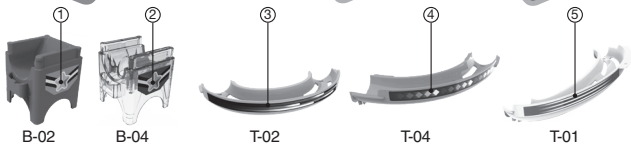
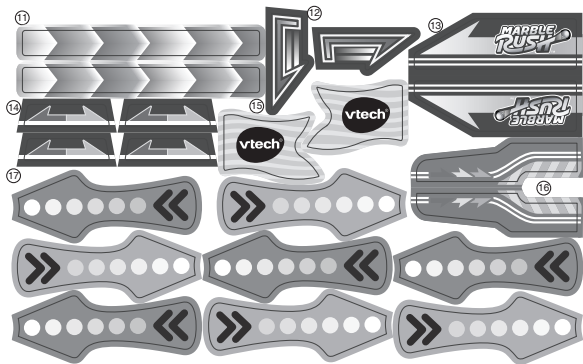

B-02

B-04

T-02

T-04

T-01



M-08

M-05

M-10

T-03

M-06

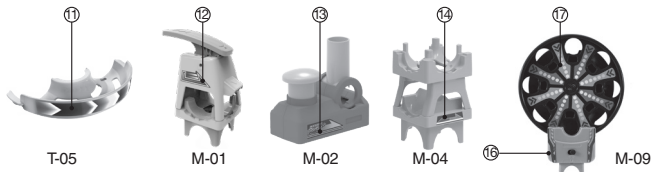

T-05

M-01

M-02

M-04

M-09

6

PRODUCT FEATURES

1. Marble Detection Sensors

When the two sensors detect a marble, the unit will make cool sound effects.



2. Music Select Buttons

Press the **Music Select Buttons** to cycle through the different background music.



3. Music/SFX Switch

Slide the switch all the way to the right to turn on both music and SFX. The middle position plays SFX only with no background music. Slide the switch all the way to the left to turn off both SFX and background music.





4. Ferris Wheel On/Off Switch

Slide the switch to turn the unit **On**, the **Ferris Wheel** will spin until the switch is turned **Off**.



5. Off/Low/High Volume Switch

To turn the unit **On** or to adjust the volume, slide the switch to the **Low**  position or the **High**  position. To turn the unit **Off**, slide the switch to the **Off**  position.

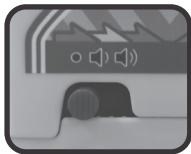

6. Automatic Shut-Off

To preserve battery life, the **Marble Rush™ Adventure Set** will automatically power-down after several minutes without input. The unit can be turned on again by sliding the **Music/SFX Switch** to a different position or by sliding the **Off/Low/High Volume Switch** to a different volume position. For the **Ferris Wheel**, you need to turn the unit off manually, as it will not automatically power off. Both units will automatically turn off when battery power is very low.

CARE & MAINTENANCE

1. Keep the unit clean by wiping it with a slightly damp cloth. Never use solvents or abrasives.
2. Keep the unit out of direct sunlight and away from any direct heat sources.
3. Remove the batteries if the unit will not be in use for an extended period of time.
4. Do not drop the unit on a hard surface and do not expose the unit to moisture or water.

TROUBLESHOOTING

If for some reason the program/activity stops working, please follow these steps:

1. Turn the unit **Off**.
2. Interrupt the power supply by removing the batteries.
3. Let the unit stand for a few minutes, then replace the batteries.
4. Turn the unit back **On**. The unit should now be ready to play with again.
5. If the unit still does not work, install a new set of batteries.

If the problem persists, please contact our Consumer Services Department, and a service representative will be happy to help you.

CONSUMER SERVICES

Creating and developing **VTech**[®] products is accompanied by a responsibility that we at **VTech**[®] take very seriously. We make every effort to ensure the accuracy of the information, which forms the value of our products. However, errors sometimes can occur. It is important for you to know that we stand behind our products and encourage you to call our Consumer Services Department with any problems and/or suggestions that you might have. A service representative will be happy to help you.

UK Customers:

Phone: 0330 678 0149 (from UK) or +44 330 678 0149 (outside UK)

Website: www.vtech.co.uk/support

Australian Customers:

Phone: 1800 862 155

Website: support.vtech.com.au

NZ Customers:

Phone: 0800 400 785

Website: support.vtech.com.au

PRODUCT WARRANTY/ CONSUMER GUARANTEES

UK Customers:

Read our complete warranty policy online at vtech.co.uk/warranty.

Australian Customers:

VTECH ELECTRONICS (AUSTRALIA) PTY LIMITED – CONSUMER GUARANTEES

Under the Australian Consumer Law, a number of consumer guarantees apply to goods and services supplied by VTech Electronics (Australia) Pty Limited. Please refer to vtech.com.au/consumerguarantees for further information.

**Visit our website for more
information about our products,
downloads, resources and more.**

www.vtech.co.uk
www.vtech.com.au

